

Dimming actuator 1..10 V with relay

KNX IO 546.1 *secure* (1D10)

Operation and installation manual



(Art. # 5337)

WEINZIERL ENGINEERING GmbH
Achatz 3-4
84508 Burgkirchen an der Alz
GERMANY

Tel.: +49 8677 / 916 36 – 0

E-Mail: info@weinzierl.de

Web: www.weinzierl.de

Content

1	Application	3
2	Installation and connection.....	3
2.1	KNX programming mode	4
2.2	Manual operation and status display	4
3	Reset to factory default settings	5
4	Wiring scheme.....	6
4.1	Pluggable screw terminals	6
4.2	Pin assignment	7
5	KNX Security	8
6	ETS database	9
6.1	Secure commissioning.....	9
6.2	Secure group communication.....	11
6.3	Description.....	13
6.4	General settings	14
6.5	Dimmer A: General.....	16
6.6	Dimmer A: Dimmer.....	19
6.7	Dimmer A: Staircase function.....	25
6.8	Dimmer A: Dimming curve	28
6.9	Dimmer A: Scene function	31
6.10	Dimmer A: Slumber function	32
6.11	Dimmer A: Lock function.....	33
6.12	Dimmer A: Sequencer	35
6.13	Actuator B: General.....	40
6.14	Actuator B: Lock function	43
6.15	Actuator B: Switch dimmer.....	45
6.16	Actuator B: Universal output	45
6.17	Actuator B: Scene function	46
6.18	Actuator B: On/Off delay	47
6.19	Actuator B: Staircase function	47
6.20	Actuator B: Valve actuator (PWM for thermal servo)	49
6.21	Logic / Timing.....	51
6.22	Function 1 – 16: Timer.....	52
6.23	Function 1 – 16: Logic	54

1 Application

The KNX IO 546.1 *secure* (1D1O) is a compact combined dimming/switching actuator with 1 dimming output for active electronic ballasts with a 0/1-10V interface and 1 bi-stable relay output.

The dimming actuator can be used for several active electronic ballasts e.g. for LED panels or stripes. The configuration allows controlling the channel by switching, rel. dimming and dimming value.

Several comfort functions are integrated as well, including scenes, slumber fading, staircase light and sequencer.

The switching actuator provides the function for universal outputs including scene control, timer, staircase lighting and heating valves (PWM for thermoelectric valve drives).

Two push buttons and three LEDs allow a local operation and a visualization of the device state.

In addition to the output channels the device includes 16 independent functions for logic or timer control.

The device supports KNX Data Security.

2 Installation and connection

The KNX IO 546.1 *secure* (1D1O) is designed for a DIN rail (35 mm) with a width of 1 unit (18 mm). An installation-friendly design with pluggable screw terminals helps to reduce costs of commissioning. The actuator has the following controls and displays:

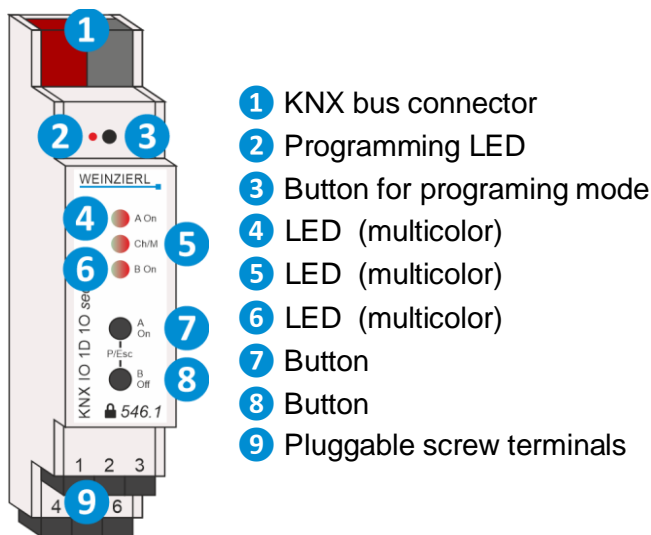

This device is powered by the KNX bus. An external power supply is not necessary.



If the bus voltage is missing, the device is without function.

2.1 KNX programming mode

The KNX programming mode is activated/deactivated either by pressing the recessed KNX programming button **3** or by simultaneously pressing the buttons (P/Esc) **7** and **8**.

When the programming mode is active, the programming LED **2** and the LED Mode **5** light up red.

The operation/visualization of the programming mode on the front can be activated/deactivated in the ETS® on page general settings.

2.2 Manual operation and status display

The LED Ch/M **5** lights up or flashes if the device is successfully powered by the KNX bus.

By pressing button A On **7** long, the manual operation mode will be entered for the dimming actuator (channel A). This is indicated by cyclic single flashing of LED Ch/M **5** in orange.

By pressing button B Off **8** long, the manual operation mode will be entered for the switching actuator (channel B). This is indicated by cyclic double flashing of LED Ch/M **5** in orange.

The respective channel can be switched on with button A On **7** and switched off with button B Off **8**. In addition, the dimming actuator (channel A) can be dimmed brighter by a long press on button A On **7** or darker on button B Off **8**. The manual operation mode can be exit by pressing the buttons (P/Esc) **7** and **8** simultaneously.

Summary of the states of LED Ch/M **5**:

LED Status	Meaning
LED lights green	The device operates in normal operating mode.
LED lights red	The programming mode is active.
LED flashes 1x orange	The programming mode is not active. Manual operation is active: Switching/Dimming of dimming actuator (channel A).
LED flashes 2x orange	The programming mode is not active. Manual operation is active: Switching of switching actuator (channel B).
LED flashes red	The programming mode is not active. Manual operation is not active. The device is not loaded correctly e.g. after aborting a download.
LED flashes green	The device is currently loaded by the ETS.

The LED A On **4** is used to display the status of the dimming actuator (channel A). It lights up green when the channel is on and is switched off when the channel is off. It lights up or flashes red if an error occurs on the device.

Summary of the states of LED A On **4**:

LED Status	Meaning
LED lights red	Error condition: No control voltage is connected to the device.
LED flashes red	Error condition: Overheating or Overload.
LED lights green	No error condition is active. Dimming actuator (channel A) is switched on.
LED is off	No error condition is active. Dimming actuator (channel A) is switched off.

The LED B On **6** is used to display the status of the switching actuator (channel B). It lights up green when the channel is on and is switched off when the channel is off.

Summary of the states of LED B On **6**:

LED Status	Meaning
LED lights green	Switching actuator (channel B) is switched on.
LED is off	Switching actuator (channel B) is switched off.

3 Reset to factory default settings

It is possible to reset the device to its factory default settings.

- Disconnect the KNX bus connector **1** from the device.
- Press the KNX programming button **3** and keep it pressed down.
- Reconnect the KNX bus connector **1** to the device.
- Keep the KNX programming button **3** pressed for at least another 6 seconds.
- A short flashing of all LEDs (**2 4 5 6**) visualizes the successful reset of the device to factory default settings.

In the factory default settings, the device has the physical address 15.15.255 and no group addresses are connected. Also, KNX Data Security is disabled and the initial key (FDSK) must be used for secure commissioning.

4 Wiring scheme

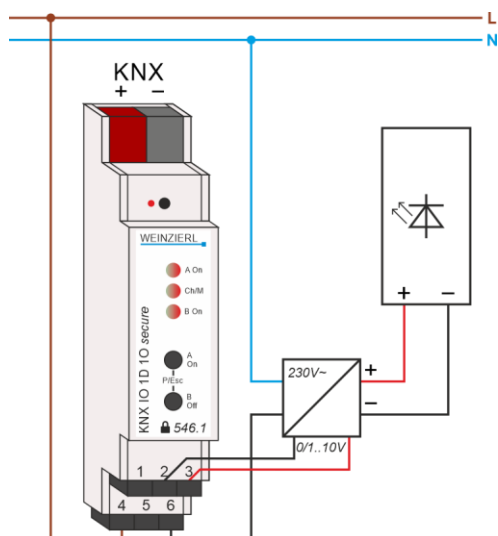

4.1 Pluggable screw terminals

	Ch A 0..10V	
	-	+
Ch B	Ch B	Ch B
Out	Out	In

Terminal top (channel A)

The top pluggable screw terminal **9** is used to control e.g. LED panels or stripes. The positive connection of the control voltage of the used electronic ballast is connected to the right terminal pin Ch A 0..10V +. The ground connection of the control voltage of the used ballast is connected to the middle terminal pin Ch A 0.10V -.

Terminal bottom (channel B)

The bottom pluggable screw terminal **9** on the left/middle terminal pins Ch B Out are used as closer. On the right terminal pin Ch B In the common pin is contacted e.g. the voltage to be switched.

4.2 Pin assignment

Connection	Icon	Description
1		Not used
2	Ch A 0..10V -	Ground connection for control voltage of electronic ballast
3	Ch A 0..10V +	Positive connection for control voltage of electronic ballast 0 ... 10 V _~
4	Ch B Out	Connection channel B Output connected as closing contact
5	Ch B Out	Connection channel B Output connected as closing contact
6	Ch B In	Common connection for channel B e.g. the voltage to be switched
KNX	+	Positive connection for KNX bus
KNX	-	Ground connection for KNX bus

5 KNX Security

The KNX standard was extended by KNX Security to protect KNX installations from unauthorized access. KNX Security reliably prevents the monitoring of communication as well as the manipulation of the system.

The specification for KNX Security distinguishes between KNX IP Security and KNX Data Security. KNX IP Security protects the communication over IP while on KNX TP the communication remains unencrypted. Thus, KNX IP Security can also be used in existing KNX systems and with non-secure KNX TP devices.

KNX Data Security describes the encryption on telegram level. This means that the telegrams on the twisted pair bus or via RF (radio frequency) are also encrypted.



Encrypted telegrams are longer than the previously used unencrypted ones. For secure programming via the bus, it is therefore necessary that the interface used (e.g. USB) and any intermediate line couplers support the so called KNX long frames.

6 ETS database

The ETS5 database (for ETS 5.7 or newer) can be downloaded from the product website of the KNX IO 546.1 *secure* (1D1O) (www.weinzierl.de) or from the ETS online catalogue.

The KNX IO 546.1 *secure* (1D1O) supports KNX Data Security to protect the device against unauthorized access from the KNX bus. If the device is programmed via the KNX bus, this is done with encrypted telegrams.

6.1 Secure commissioning

If the first product is inserted into a project with KNX Security, the ETS prompts you to enter a project password.

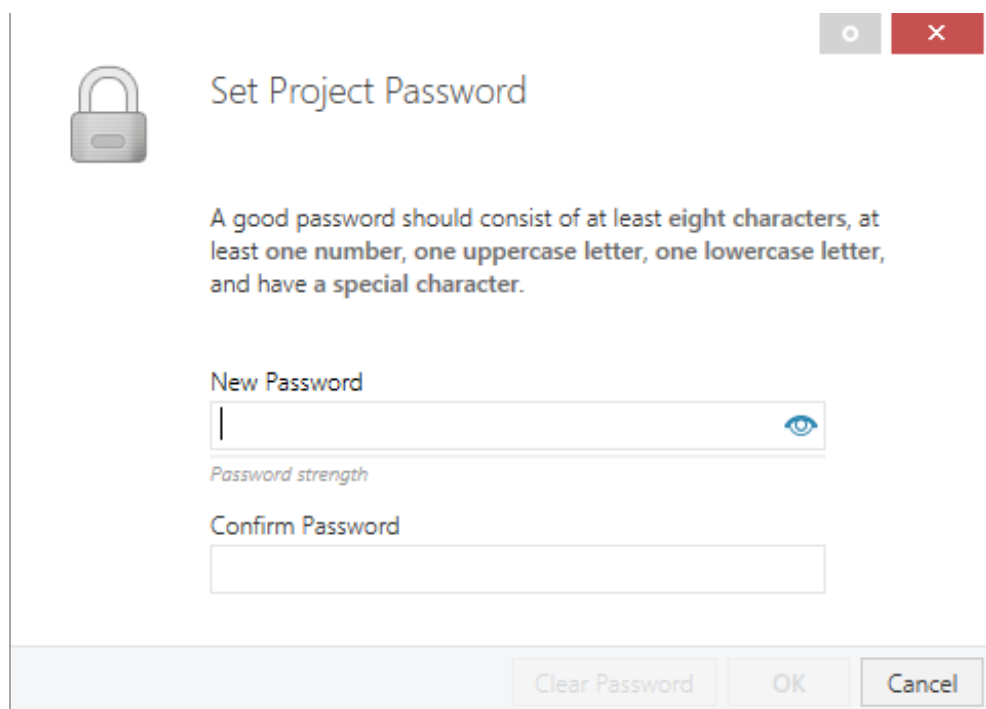

This password protects the ETS project from unauthorized access. This password is not a key that is used for KNX communication. The entry of the password can be bypassed with "Cancel", but this is not recommended for security reasons.

ETS requires a device certificate for each device with KNX Security that is created in the ETS. This certificate contains the serial number of the device as well as an initial key (FDSK = Factory Default Setup Key).

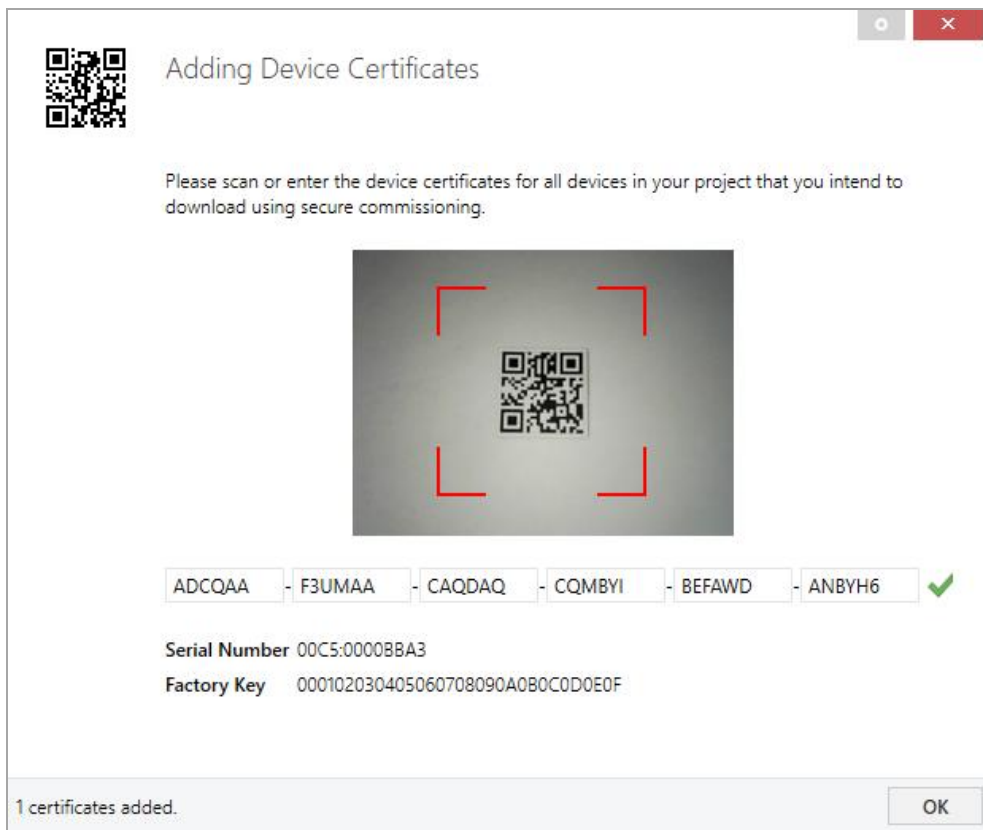

The certificate is printed as text on the device. It can also be scanned from the printed QR code via a webcam.

The list of all device certificates can be managed in the ETS panel Reports – Project Security.

This initial key is required to safely put a device into operation from the start. Even if the ETS download is recorded by a third party, the third party has no access to the secured devices afterwards. During the first secure download, the initial key is replaced by the ETS with a new key that is generated individually for each device. This prevents persons or devices who may know the initial key from accessing the device. The initial key is reactivated after a reset to factory default settings.

The serial number in the certificate enables the ETS to assign the correct key to a device during a download.

In the ETS project in the properties of the device, secure commissioning can be activated and the device certificate can be added:

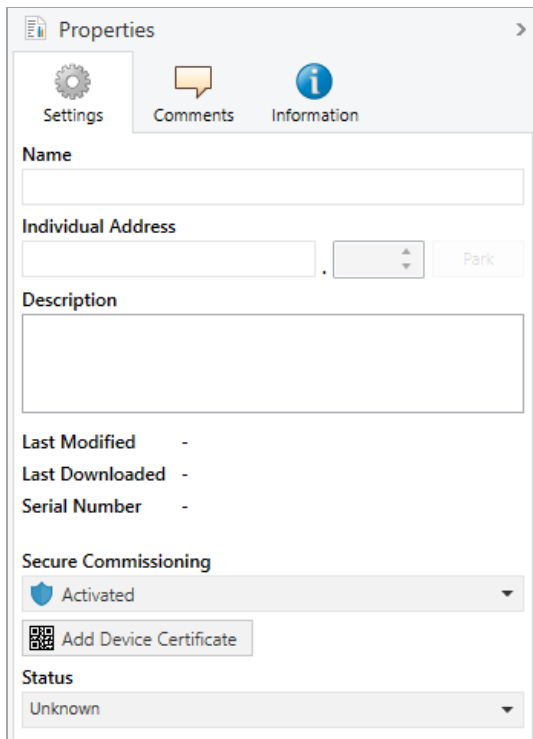





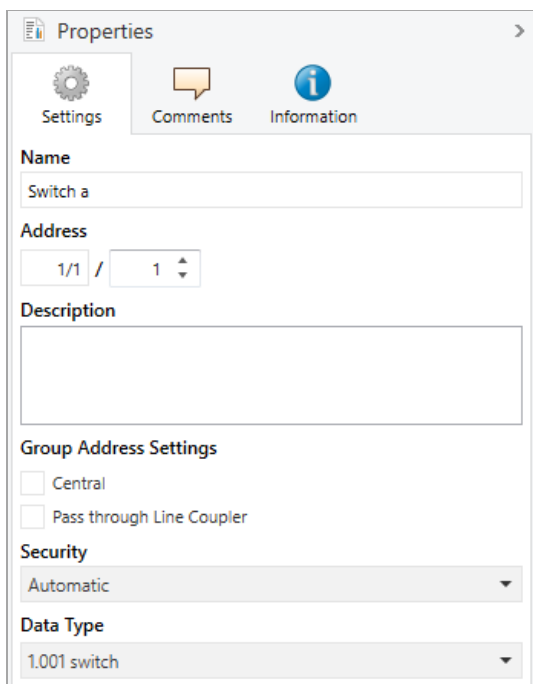

6.2 Secure group communication

Each object of the device can communicate either encrypted or unencrypted. The encryption is set under "Security" in the properties of the used group address:



The setting "Automatic" activates encryption if both objects to be connected can communicate encrypted. Otherwise encrypted communication between the objects is not possible.

In the overview of communication objects in the ETS project, secured objects can be recognized by a shield symbol:

	Security	Number ^	Name	Object Function	Description	Group Address
		11	Button A0: Object a	Switch	Switch a	1/1/1
		12	Button A0: Object b	Switch	Switch b	1/1/2
		21	Button A1: Object a	Switch	Switch a	1/1/1
		22	Button A1: Object b	Switch	Switch b	1/1/2

A separate key is automatically generated by the ETS for each secured group address. These keys can also be checked in the ETS panel Reports – Project Security. To enable all devices to communicate with a secure group address, the keys must be known to all. Therefore a download must be made into all devices that use this group address when a key is created or changed. A key is changed by the ETS e.g. when the encryption of a group address is switched off and on again.

6.3 Description

--.- KNX IO 546.1 secure (1D10) > Description	
<p>Description</p> <p>KNX IO 546.1 secure (1D10) Combined dimming/switching actuator with 1 dimming output for active electronic ballasts and 1 switching output</p>	
<p>General settings</p> <p>+ Channel A: Dimmer</p> <p>+ Channel B: Actuator</p> <p>+ Logic / Timer</p>	<p>WEINZIERL</p> <hr/> <p>The KNX IO 546.1 secure (1D10) is a compact combined dimming/switching actuator with 1 dimming output for active electronic ballasts with a 0/1-10V interface and 1 bi-stable relay output.</p> <p>The dimming actuator can be used for several active electronic ballasts e.g. for LED panels or stripes. The configuration allows controlling the channel by switching, rel. dimming and dimming value.</p> <p>Several comfort functions are integrated as well, including scenes, slumber fading, staircase light and sequencer.</p> <p>The switching actuator provides the function for universal outputs including scene control, timer, staircase lighting and heating valves (PWM for thermoelectric valve drives).</p> <p>Two push buttons and three LEDs allow a local operation and a visualization of the device state.</p> <p>In addition to the output channels the device includes 16 independent functions for logic or timer control.</p> <p>The device supports KNX Data Security.</p>
<p>Wiring scheme:</p>	
<p>Please consult device data sheet and manual for further information.</p>	
<p>Contact:</p> <p>WEINZIERL ENGINEERING GmbH Achatz 3-4 84508 Burgkirchen an der Alz GERMANY www.weinzierl.de info@weinzierl.de</p>	

This page shows the device description and the corresponding connection diagram.

6.4 General settings

--.- KNX IO 546.1 secure (1D10) > General settings		
Description	Device name	KNX IO 546.1 secure (1D10)
General settings	Send delay after bus power return	5 s
+ Channel A: Dimmer	Prog. mode on device front	<input type="radio"/> Disabled <input checked="" type="radio"/> Enabled
+ Channel B: Actuator	Manual operation on device	Enabled with time limit 10 min
+ Logic / Timer	Heartbeat	<input type="radio"/> Disabled <input checked="" type="radio"/> Enabled
	Cycle time	5 min
	Telegram rate limitation	1.0 s
	Alarm objects for error conditions	<input checked="" type="radio"/> Disabled <input type="radio"/> Enabled
	Dimming control	<input type="radio"/> 0...10 V <input checked="" type="radio"/> 1...10 V

Device name (30 characters)

Any name can be assigned for the KNX IO 546.1 *secure* (1D10). The device name should be meaningful, e.g. "Living room EG". This helps the clarity in the ETS project.

Send delay after bus power return

The parameter Send delay after bus power return can be used to set a delay of telegrams after bus power return. Telegrams are sent from the device to the KNX bus with a delay of the set time. This has the effect of reducing the bus load on bus power return. Other functions such as telegram reception or switching operations of the actuator are not influenced by this parameter.

Prog. mode on device front

In addition to the normal programming button **3**, the device allows you to activate the programming mode on the device front without opening the panel cover. Programming mode can be activated and deactivated by pressing keys **7** and **8** simultaneously.

This function can be switched on and off via the parameter Prog. Mode on the device front. The recessed programming button **3** (next to the programming LED **2**) is always enabled and is not affected by this parameter.

Manual operation on the device

This parameter is used to configure manual operation on the device. Manual operation mode can be disabled or enabled (with or without time limit). The time limit defines the duration until the automatic return from manual operation back to normal operating mode.

The device is in normal operating mode when manual operation is not active. In manual operation mode, received switching telegrams are stored. When manual operation is terminated (after the time limit has expired or manually), the last switching telegram received is executed.

The following configuration options are available:

- Disabled
- Enabled with time limit 1 min
- Enabled with time limit 10 min
- Enabled with time limit 30 min
- Enabled without time limit

Heartbeat

Sends values cyclically to the KNX bus to indicate that the device is currently ready for operation. The cycle time can be selected between 1 minute and 24 hours.

Group object	Type KNX	Size	Direction
GO 1 Heartbeat – Trigger	1.001	1 bit	To KNX

Telegram rate limitation

With this parameter the telegram rate limitation can be activated and the time between telegrams can be configured. Times between 0.1 s and 1.0 s can be selected.



The telegram rate limitation only occurs when the bus load is increased.

Alarm objects for error conditions

This parameter makes the following objects visible for visualization of error states:

Group object	Type KNX	Size	Direction
GO 2 Alarm – Overload	1.001	1 bit	To KNX
GO 3 Alarm – Overtemperature	1.001	1 bit	To KNX
GO 4 Alarm – No control voltage	1.001	1 bit	To KNX

When an error state is detected, all dimmer outputs switch off and an ON telegram is sent via the respective object. The outputs are disabled for the duration of the error state. Once this has been rectified, the respective object sends an OFF telegram and the dimmer can be operated normally again.

Overload and overtemperature triggered from a measured temperature of 85 °C in the device. If no value is received from the load section for longer than 3 seconds, this triggers the error state “No control voltage”.

Dimming control

Here it can be switched between the control of the dimmer output with 0...10 V or 1...10 V.

6.5 Dimmer A: General

--.- KNX IO 546.1 secure (1D10) > Channel A: Dimmer > Dimmer A: General	
Description	Name <input type="text"/>
General settings	Function <input type="text" value="Dimmer"/>
- Channel A: Dimmer	Send state <input type="text" value="Cyclic and on change"/>
	Time for cyclic state <input type="text" value="6 hour"/>
Dimmer A: General	Behavior on bus power loss <input type="radio"/> No reaction <input checked="" type="radio"/> Dimm to value
Dimmer A: Dimmer	Dimming value <input type="text" value="100"/> %
Dimmer A: Dimming curve	Behavior after bus power return <input type="text" value="Dimm to value"/>
Dimmer A: Sequencer	Dimming value <input type="text" value="100"/> %
+ Channel B: Actuator	Scene function <input checked="" type="radio"/> Disabled <input type="radio"/> Enabled
+ Logic / Timer	Automatic mode <input checked="" type="radio"/> Disabled <input type="radio"/> Enabled
	Slumber function <input checked="" type="radio"/> Disabled <input type="radio"/> Enabled
	Lock function <input checked="" type="radio"/> Disabled <input type="radio"/> Enabled

Name (30 characters)

Any name can be assigned to the channel. However, this should be unique and meaningful, this makes it easier to work with the associated group objects later, as the assigned name is displayed there as a designation. If no name is assigned, the group objects are labelled “Dimmer A: ...”.

Function

This parameter defines the functionality of the actuator. The following options are available:

- Disabled
- Dimmer

In this operating mode, scene function, automatic mode, slumber and lock function are available. In the “Dimmer” operating mode, objects can be configured for switching on/off, relative dimming, control of the dimmer via dimming and RGB value. The “Dimmer A: Dimmer” parameter page is displayed for this purpose.
- Staircase function

A parameter page “Dimmer A: Staircase function” is displayed. Only the lock function is available in this operating mode.

Send state

This parameter defines the send behavior of the state objects:

- Disabled
State objects are disabled and hidden.
- Only on read
State objects send only for read requests.
- On change
The switch object sends an off telegram when the output value changes to 0 %, an on telegram when the output value changes from 0 % to a value greater than 0 %. The value object sends with a time interval of at least 1 second when the value at the output has changed by at least 1 %, or when a dimming operation has been completed.
- Cyclically and on change
State objects send cyclically and on value change.

Group object	Type KNX	Size	Direction
GO 16 Dimmer A: Dimming output – State on/off	1.001	1 bit	To KNX
GO 17 Dimmer A: Dimming output – State value	5.001	1 byte	To KNX

Time for cyclic state *(only for “Cyclic and on change”)*

If send state is configured with “Cyclic and on change”, this parameter appears to set the cycle time for sending.

Behavior on bus power loss

The behavior of the output in the event of bus voltage failure can be configured here.

The choices are:

- No reaction
- Dimm to value

Behavior after bus power return

The behavior of the output after bus power return can be configured here. This behavior is executed at every device restart (e.g. also at restart after an ETS download).

The choices are:

- No reaction
- Dimm to value
- State like before bus power failure

Scene function *(only with “Dimmer” function)*

The scene function can be activated or deactivated here. It is only available in the “Dimmer” function. If this functionality is activated, a parameter page appears for further configuration of scenes 1 – 16. The further functionality is explained in section “Dimmer A: Scene function”.

Automatic mode *(only with “Dimmer” function)*

Automatic mode is only available in the “Dimmer” function. If this function is selected, the following objects become visible:

Group object	Type KNX	Size	Direction
GO 19 Dimmer A: Automatic mode – Activate	1.001	1 bit	From KNX To KNX
GO 20 Dimmer A: Autom. dimming abs. – Set value	5.001	1 byte	From KNX

When using automatic mode, the dimmer can be controlled via object 20, e.g. for light control or daylight-dependent basic lighting.

In automatic mode, the dimmer can be manually overridden by dimming on/off, dimming rel., dimming value, scene, slumber function or sequencer. During manual override, values of object 20 are ignored, each further manual override restarts the fallback time.

After the fallback time set in the parameter has elapsed, the values received on object 20 are processed again.

The automatic mode can be switched on or off at any time via object 19, it also serves as a state object for automatic mode.

Slumber function *(only with “Dimmer” function)*

The slumber function is only available in the “Dimmer” function. The slumber function offers 2 different dimming times each for switching on and off via object. If this function is activated, a new parameter page appears, which is explained in section “Dimmer A: Slumber function”.

Lock function

The disable function can be activated or deactivated here. This function is available in both functions “Dimmer” and “Staircase function”. If this functionality is activated, a new parameter page appears for further configuration, which is explained in more detail in section “Dimmer A: Lock function”.

6.6 Dimmer A: Dimmer

Object Dimming on/off

--- KNX IO 546.1 secure (1D10) > Channel A: Dimmer > Dimmer A: Dimmer

Description	Object Dimming on/off	<input type="radio"/> Disabled <input checked="" type="radio"/> Enabled
General settings	Behavior on ON telegram (when dimmer is off)	Dimm to fix value
Channel A: Dimmer	Behavior on ON telegram (when dimmer is on)	Dimm to fix value
Dimmer A: General	Dimming value on ON telegram	100 %
Dimmer A: Dimmer	Fade time on ON telegram (related to 100%)	00:00:00 hh:mm:ss
Dimmer A: Dimming curve	Behavior on OFF telegram	<input type="radio"/> No reaction <input checked="" type="radio"/> Dimm to fix value
Dimmer A: Sequencer	Dimming value on OFF telegram	0 %
Channel B: Actuator	Behavior on 2nd OFF telegram	<input checked="" type="radio"/> No reaction <input type="radio"/> Switch off
Logic / Timer	Fade time on OFF telegram (related to 100%)	00:00:00 hh:mm:ss
	Day/night switching	Switch on day/night telegram
	Dimming value on ON telegram (night)	50 %
	Dimming value on OFF telegram (night)	0 %
	Fade time for day/night switching (related to 100%)	00:00:04 hh:mm:ss
	Object Dimming rel.	<input checked="" type="radio"/> Disabled <input type="radio"/> Enabled
	Object Dimming value	<input checked="" type="radio"/> Disabled <input type="radio"/> Enabled
	Object RGB value	<input checked="" type="radio"/> Disabled <input type="radio"/> Enabled

The following objects are available for switching the dimmers if they have been activated via parameters:

Group object	Type KNX	Size	Direction
GO 11 Dimmer A: Dimming on/off – Switch	1.001	1 bit	From KNX

Behavior on ON telegram (when dimmer is off)

If the dimmer is switched off, this parameter can be used to configure the behavior when switching on via object 11.

The choices are:

- No reaction
- Dimm to fix value
- Dimm to last value before switching off

Behavior on ON telegram (when dimmer is on)

If the dimmer is already switched on, this parameter can be used to configure the behavior in the event of a renewed ON telegram via object 11.

The choices are:

- No reaction
- Dimm to fix value
- Dimm to fix value if higher than actual

Dimming value on ON telegram

With suitable parameterisation, this value is activated with an ON telegram via object 11.

Fade time on ON telegram (related to 100%)

This dimming time is active when an ON telegram is received. The time period is related to a complete dimming process from 0 – 100 %.

Behavior on OFF telegram

This parameter describes the behavior of the dimmer in the event of an OFF telegram via object 11.

The choices are:

- No reaction
- Dimm to fix value

Dimming value on OFF telegram

With suitable parameterisation, this value is activated with an OFF telegram via object 11.

Behavior on 2nd OFF telegram

This parameter describes the behavior of the dimmer when a 2nd OFF telegram is received via object 11.

The choices are:

- No reaction
- Switch off

The 2nd OFF telegram must follow the 1st OFF telegram within 1 second in order to be evaluated. If the current dimming value is equal to or lower than the parameterised dimming value for the OFF telegram, switching off takes place with the 1st OFF telegram.

Fade time on OFF telegram (related to 100%)

This dimming time is active when an OFF telegram is received. The time period is related to a complete dimming process from 0 – 100 %.

Day/night switching

When using this function, the following objects are visible for switching from day/night mode:

Group object	Type KNX	Size	Direction
GO 15 Dimmer A: Day/Night – Switch	1.001	1 bit	From KNX

Day mode is triggered with an ON telegram to object 15, night mode with an OFF telegram. The device is in day mode after restart.

In addition, it can be determined when the dimming values become active after telegram via object 15 are available for selection:

- Disabled
- Switch on day/night telegram
Immediately after day/night switching is received, dimming is set to the active dimming value in accordance with the last ON/OFF switching received via object 11.
- Switch on next on/off telegram
The currently active dimming value is not used until the next ON/OFF switching via object 11.

There is a separate switch-on and switch-off value in the parameters for night mode, in day mode the always visible dimming values are used.

Dimming value on ON telegram (night) *(only with active day/night switching)*

If the dimmer is in night mode, this value is activated with an ON telegram via object 11 and suitable parameterisation.

Dimming value on OFF telegram (night) *(only with active day/night switching)*

If the dimmer is in night mode, this value is activated with an OFF telegram via object 11 and suitable parameterisation.

Fade time for day/night switching (related to 100%)

(only with active day/night switching)

This dimming time is only active if switching is used with day/night switching. If switching is used with the next on/off telegram, the regular dimming time of the respective on or off telegram is active. The time period is related to a complete dimming process from 0 – 100 %.

Object Dimming rel.

--- KNX IO 546.1 secure (1D10) > Channel A: Dimmer > Dimmer A: Dimmer

Description	Object Dimming on/off	<input checked="" type="radio"/> Disabled <input type="radio"/> Enabled
General settings	Object Dimming rel.	<input type="radio"/> Disabled <input checked="" type="radio"/> Enabled
Channel A: Dimmer	Minimal dimming value while dimming with object	<input type="text" value="0"/> %
Dimmer A: General	Maximal dimming value while dimming with object	<input type="text" value="100"/> %
Dimmer A: Dimmer	Fade time while dimming brighter with object (related to 100%)	<input type="text" value="00:00:04"/> hh:mm:ss
Dimmer A: Dimming curve	Fade time while dimming darker with object (related to 100%)	<input type="text" value="00:00:04"/> hh:mm:ss
Dimmer A: Sequencer	Object Dimming value	<input checked="" type="radio"/> Disabled <input type="radio"/> Enabled
Channel B: Actuator	Object RGB value	<input checked="" type="radio"/> Disabled <input type="radio"/> Enabled
Logic / Timer		

The following objects are available for dimming via relative dimming commands if they have been activated via parameters:

Group object	Type KNX	Size	Direction
GO 12 Dimmer A: Dimming rel. – Brighter/Darker	3.007	4 bits	From KNX

Minimal dimming value while dimming with object

This parameter can be used to set which minimum dimming value can be reached via relative dimming. If the current dimming value is below the minimum value, the brightness cannot be reduced via object 12.

Maximal dimming value while dimming with object

This parameter can be used to set which maximum dimming value can be reached via relative dimming. If the current dimming value is above the maximum value, the brightness cannot be increased via object 12.

Fade time while dimming brighter with object (related to 100%)

This dimming time is active when the brightness is increased via relative dimming with object 12. The time period is related to a complete dimming process from 0 – 100 %.

Fade time while dimming darker with object (related to 100%)

This dimming time is active when the brightness is reduced via relative dimming with object 12. The time period is related to a complete dimming process from 0 – 100 %.

Object Dimming value

--- KNX IO 546.1 secure (1D10) > Channel A: Dimmer > Dimmer A: Dimmer

Description	Object Dimming on/off	<input checked="" type="radio"/> Disabled <input type="radio"/> Enabled
General settings	Object Dimming rel.	<input checked="" type="radio"/> Disabled <input type="radio"/> Enabled
Channel A: Dimmer	Object Dimming value	<input type="radio"/> Disabled <input checked="" type="radio"/> Enabled
Dimmer A: General	Minimal dimming value for changing dimming value by object	<input type="text" value="10"/> %
Dimmer A: Dimmer	Switch off dimmer with telegram value 0%	<input type="radio"/> Disabled <input checked="" type="radio"/> Enabled
Dimmer A: Dimming curve	Maximal dimming value for changing dimming value by object	<input type="text" value="100"/> %
Dimmer A: Sequencer	Fade time while dimming brighter with object (related to 100%)	<input type="text" value="00:00:04"/> hh:mm:ss
Channel B: Actuator	Fade time while dimming darker with object (related to 100%)	<input type="text" value="00:00:04"/> hh:mm:ss
Logic / Timer	Object RGB value	<input checked="" type="radio"/> Disabled <input type="radio"/> Enabled

The following objects are used to control the dimmer via dimming value if they have been activated via parameters:

Group object	Type KNX	Size	Direction
GO 13 Dimmer A: Dimming abs. – Set value	5.001	1 byte	From KNX

Minimal dimming value for changing dimming value by object

This parameter can be used to configure which minimum dimming value can be reached via object 13. If a value below the minimum value is received, the dimmer is controlled with the minimum value. If a value > 0 % is set here, the parameter **Switch off dimmer with telegram value 0%** is also visible.

Switch off dimmer with telegram value 0%

(only with "Minimal dimming value for changing dimming value by object" > 0 %)

Here you can select whether the dimmer is switched off when a dimming value of 0 % is received.

Maximal dimming value for changing dimming value by object

This parameter can be used to configure which maximum dimming value can be reached via object 13. If a value above the maximum value is received, the dimmer is controlled with the maximum value.

Fade time while dimming brighter with object (related to 100%)

This dimming time is active if the brightness is increased when values are received via object 13. The time period is related to a complete dimming process from 0 – 100 %.

Fade time while dimming darker with object (related to 100%)

This dimming time is active if the brightness is reduced when values are received via object 13. The time period is related to a complete dimming process from 0 – 100 %.

Object RGB value

--- KNX IO 546.1 secure (1D10) > Channel A: Dimmer > Dimmer A: Dimmer

Description	Object Dimming on/off	<input checked="" type="radio"/> Disabled <input type="radio"/> Enabled
General settings	Object Dimming rel.	<input checked="" type="radio"/> Disabled <input type="radio"/> Enabled
Channel A: Dimmer	Object Dimming value	<input checked="" type="radio"/> Disabled <input type="radio"/> Enabled
Dimmer A: General	Object RGB value	<input type="radio"/> Disabled <input checked="" type="radio"/> Enabled
Dimmer A: Dimmer	RGB value usage	Use brightness (max. value of red, green, blue)
Dimmer A: Dimming curve	Minimal value for changing color by object	0
Dimmer A: Sequencer	Maximal value for changing color by object	255
Channel B: Actuator	Fade time while dimming brighter with object (related to 100%)	00:00:04 hh:mm:ss
Logic / Timer	Fade time while dimming darker with object (related to 100%)	00:00:04 hh:mm:ss

To control the dimmer via RGB color value, the following objects are available if activated via parameters:

Group object	Type KNX	Size	Direction
GO 14 Dimmer A: RGB color value – Set value	232.600	3 bytes	From KNX

RGB value usage

Here you can set how a received RGB color value is to be processed:

- Use red part
The 1st byte of the RGB value (red) is used to control the brightness of the dimmer.
- Use green part
The 2nd byte of the RGB value (green) is used to control the brightness of the dimmer.
- Use blue part
The 3rd byte of the RGB value (blue) is used to control the brightness of the dimmer.
- Use white (min. value of red, green, blue)
The smallest value of the 3 bytes is used to control the brightness of the dimmer.
- Use brightness (max. value of red, green, blue)
The largest value of the 3 bytes is used to control the brightness of the dimmer.

Minimal value for changing color by object

This parameter can be used to configure which minimum dimming value can be set via object 14. If a value below the minimum value is received, the dimmer is controlled with the minimum value.

Maximal value for changing color by object

This parameter can be used to configure which maximum dimming value can be set via object 14. If a value above the maximum value is received, the dimmer is controlled with the maximum value.

Fade time while dimming brighter with object (related to 100%)

This dimming time is active if the brightness is increased when values are received via object 14. The time period is related to a complete dimming process from 0 – 100 %.

Fade time while dimming darker with object (related to 100%)

This dimming time is active if the brightness is reduced when values are received via object 14. The time period is related to a complete dimming process from 0 – 100 %.

6.7 Dimmer A: Staircase function

--- KNX IO 546.1 secure (1D10) > Channel A: Dimmer > Dimmer A: Staircase function

Description	Dimming value on switching on staircase function (day)	100 %
General settings	Dimming value on switching on staircase function (night)	50 %
Channel A: Dimmer	Fade time for switching on (related to 100%)	00:00:01 hh:mm:ss
Dimmer A: General	Delay time of staircase function	10 min
Dimmer A: Staircase function	Reaction on ON telegram	<input type="radio"/> Switch on <input checked="" type="radio"/> Switch to switch-off delay
Dimmer A: Dimming curve	Delay time retriggerable	<input type="radio"/> Disabled <input checked="" type="radio"/> Enabled
Dimmer A: Sequencer	Orientation light after delay time	30 s
Channel B: Actuator	Dimming value while orientation light	20 %
Logic / Timer	Fade time for orientation light (related to 100%)	00:00:10 hh:mm:ss
	Reaction on OFF telegram	Ignore
	Dimming value on switching off staircase function (day)	0 %
	Dimming value on switching off staircase function (night)	10 %
	Fade time for switching off (related to 100%)	00:01:00 hh:mm:ss

A staircase function with optional orientation light can be implemented via this parameter page. The staircase function can be overridden by the disable function. It has the following objects:

Group object	Type KNX	Size	Direction
GO 11 Dimmer A: Staircase function – Trigger	1.010	1 bit	From KNX
GO 15 Dimmer A: Day/Night – Switch	1.001	1 bit	From KNX

Day mode is triggered with an ON telegram to object 15, night mode with an OFF telegram. The device is in day mode after restart.

Dimming value on switching on staircase function (day)

This value is used in day mode when the staircase function is switched on via an ON telegram to object 11.

Dimming value on switching on staircase function (night)

This value is used in night mode if the staircase function is switched on via an ON telegram to object 11.

Fade time for switching on (related to 100%)

This dimming time is active when the staircase function is switched on via an ON telegram to object 11. The time period is related to a complete dimming process from 0 – 100 %.

Delay time of staircase function

After the delay time has elapsed, the dimmer is dimmed to the switch-off or orientation light value, depending on the parameter setting.

Reaction on ON telegram

This parameter determines the behavior after switching on the staircase function via ON telegram to object 11: In the setting “Switch on”, the channel remains switched on after ON telegram until the delay time is started via OFF telegram. In the “Switch to switch-off delay” setting, the channel goes immediately into the delay time after the ON telegram.

Delay time retriggerable

If it is set that the delay time is started with an ON telegram, this parameter determines whether only the 1st ON telegram to object 11 restarts the delay time, or also each subsequent ON telegram.

If it is set that the overshoot time is started with an OFF telegram, this parameter determines whether only the 1st OFF telegram to object 11 restarts the overshoot time, or also each further one if the staircase function is already in the overshoot time.

Orientation light after delay time

This parameter can be used to set whether the dimmer dims to the switch-off value or to the orientation light after the end of the delay time, as well as the duration of the orientation light.

To choose from:

- Disabled
- 1 s
- 2 s
- 5 s
- 10 s
- 30 s
- 1 min
- 2 min
- 5 min
- 10 min
- 20 min
- 30 min
- 1 h
- 2 h
- Without timelimit

Dimming value while orientation light

This value is dimmed to at the end of the delay time if orientation light is used.

Fade time for orientation light (related to 100%)

This dimming time is active when the staircase function dims to orientation light. The time period is related to a complete dimming process from 0 – 100 %.

Reaction on OFF telegram

Here you can set how the staircase function behaves in the event of an Off telegram. The following options are available:

- Ignore
No reaction of the channel in case of off telegram.
- Switch off
Switches to switch-off value from the parameters.
- Switch to switch-off delay
The delay time is started with an OFF telegram.
- Switch to orientation light
The orientation light phase is started with an OFF telegram.
- Switch to orientation light/switch off
With the 1st OFF telegram the orientation light phase is started, with the 2nd OFF telegram it is dimmed to the switch-off value.

Dimming value on switching off staircase function (day)

This value is dimmed in day mode if the staircase function is switched off after the delay time or via an OFF telegram to object 11.

Dimming value on switching off staircase function (night)

This value is dimmed in night mode if the staircase function is switched off after the delay time or via an OFF telegram to object 11.

Fade time for switching off (related to 100%)

This dimming time is active when the staircase function dims to the OFF value. The time period is related to a complete dimming process from 0 – 100 %.

6.8 Dimmer A: Dimming curve

--- KNX IO 546.1 secure (1D10) > Channel A: Dimmer > Dimmer A: Dimming curve			
Description	Dimming curve	Linear	▼
General settings	Dimming output at 0%	0	%
	Dimming output at 10%	10	%
- Channel A: Dimmer	Dimming output at 20%	20	%
	Dimming output at 30%	30	%
	Dimming output at 40%	40	%
	Dimming output at 50%	50	%
	Dimming output at 60%	60	%
	Dimming output at 70%	70	%
	Dimming output at 80%	80	%
	Dimming output at 90%	90	%
	Dimming output at 100%	100	%
	+	Adjustment of channel	100

This parameter page is used for fine adjustment of the dimmer to different lamps.



All parameters on this page only affect the control voltage of the output, not the dimming or output state value.

Dimming curve

Here you can define which control voltage is output by the dimming output when the dimming channel has reached a certain dimming value. The following are available for selection:

- Linear
- Logarithmic
- User defined

- Gamma

Gamma correction according to the formula: $Control\ voltage = Dimming\ value^{gamma}$

Gamma can be set via parameter from 1.00 ... 5.00.

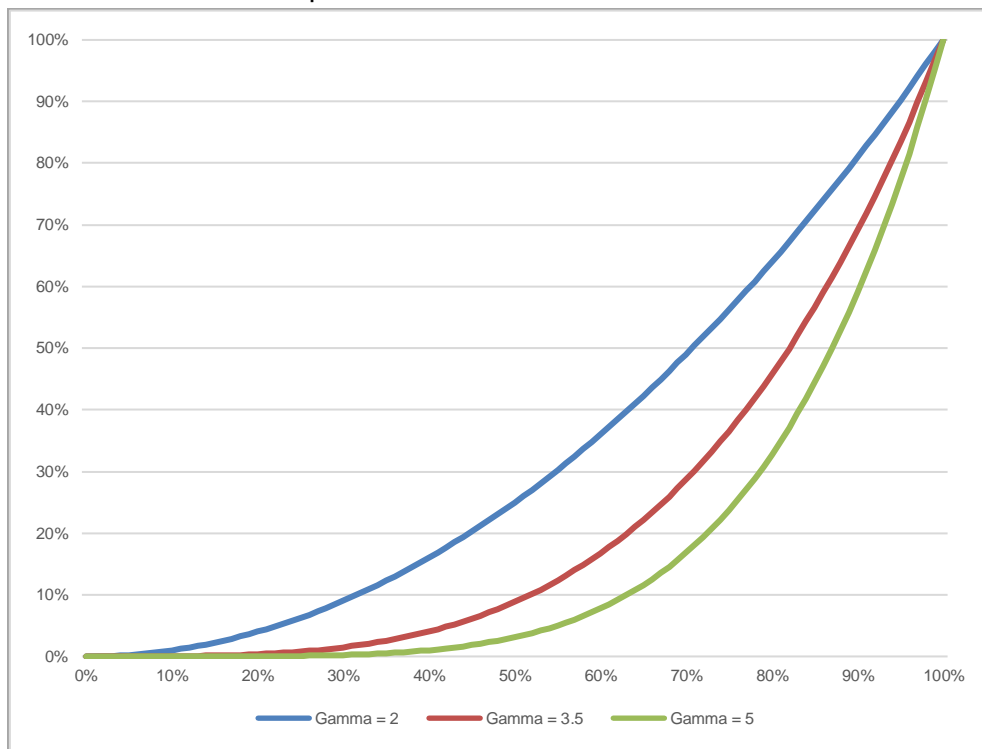

- DALI

An DALI based function with the formula: $Control\ voltage = 10^{3 \cdot (Dimming\ value - 1)}$

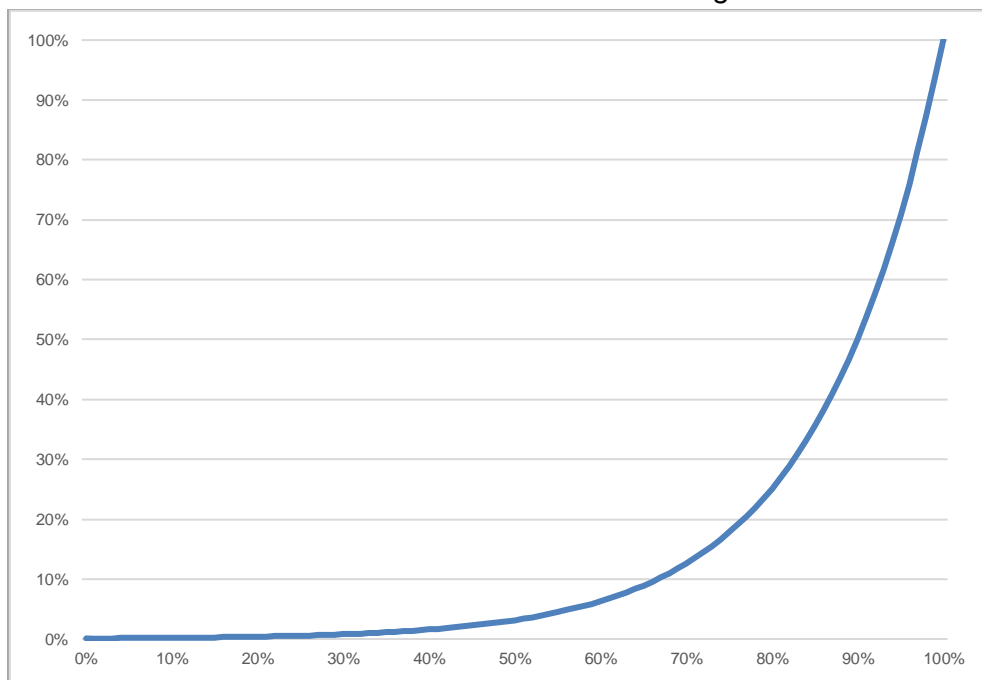

Dimming output at 0% – 100%

For the dimming curves “Linear”, “Logarithmic” and “User defined”, these values determine the control voltage of the dimming output at the specified dimming value. Values between the specified points are calculated and output linearly. As an example, the dimming output behaves according to the following graph for dimming curve “Logarithmic”:

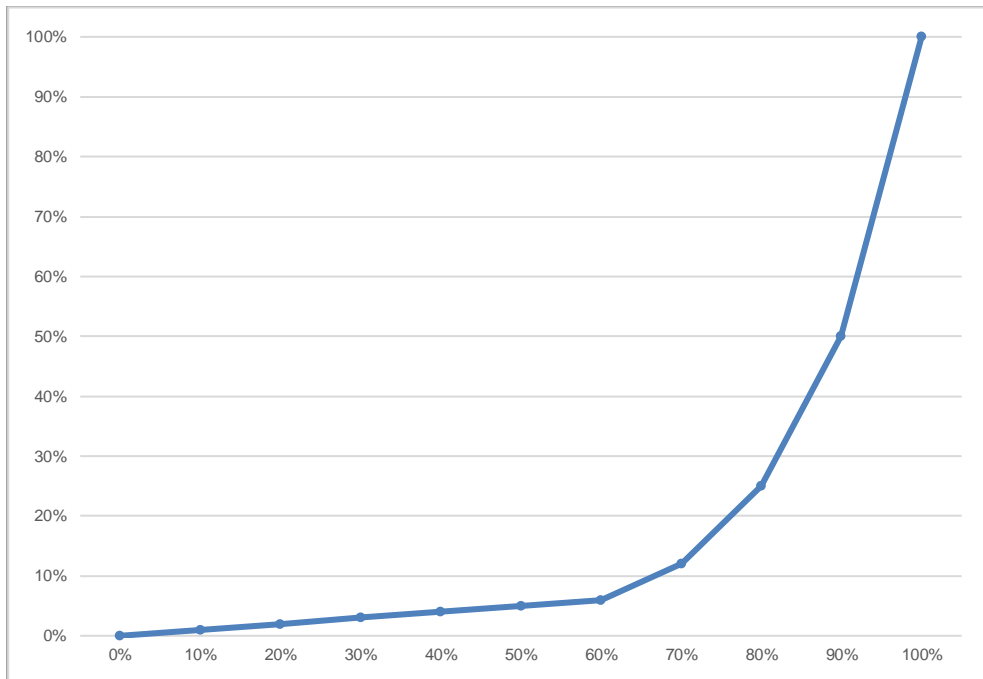

For the dimming curves “Linear” and “Logarithmic” the output values are fixed, for “User defined” they can be freely configured.



If a dimming value of 0 % is reached, the channel always switches off.

Adjustment of channel

The control voltage calculated by the dimming curve is additionally scaled with this value.

6.9 Dimmer A: Scene function

--- KNX IO 546.1 secure (1D10) > Channel A: Dimmer > Dimmer A: Scene function

Description	Fade time on activation of scene (related to 100%)	<input type="text" value="00:00:04"/> hh:mm:ss
General settings	Scene 1	Dimming value
Channel A: Dimmer	Number	<input type="text" value="1"/>
Dimmer A: General	Dimming value	<input type="text" value="10"/> %
Dimmer A: Dimmer	Scene 2	Learnable
Dimmer A: Dimming curve	Number	<input type="text" value="2"/>
Dimmer A: Scene function	Scene 3	Dimming value
Dimmer A: Sequencer	Number	<input type="text" value="3"/>
Channel B: Actuator	Dimming value	<input type="text" value="30"/> %
Logic / Timer	Scene 4	Learnable
	Number	<input type="text" value="4"/>
	Scene 5	No reaction
	Scene 6	No reaction
	Scene 7	No reaction
	Scene 8	No reaction
	Scene 9	No reaction
	Scene 10	No reaction
	Scene 11	No reaction
	Scene 12	No reaction
	Scene 13	No reaction
	Scene 14	No reaction
	Scene 15	No reaction
	Scene 16	No reaction

If the scene function is activated, the following group objects appear:

Group object	Type KNX	Size	Direction
GO 18 Dimmer A: Scene – Activ./Lrn.	18.001	1 byte	From KNX

Fade time on activation of scene (related to 100%)

The time period in which the received scene is dimmed is set here. The time period is related to a complete dimming process from 0 – 100 %.

Scene 1 – 16

These parameters can be used to configure the reaction of the channel when the respective scene is received.

The choices are:

- No reaction
- Dimming value
The output is switched to the set dimming value if the scene of the corresponding number was received.

- Learnable

Here, the current state at the output for the respective scene can be saved with the help of a scene control telegram. Thus, the scene can be adapted by the user without ETS download.

Number

This parameter can be used to assign any scene number between 1 and 64 to the scene. No scene numbers may be assigned twice.

6.10 Dimmer A: Slumber function

If the slumber function is selected, the following objects are visible:

Group object	Type KNX	Size	Direction
GO 21 Dimmer A: Slumber function – Trigger	1.001	1 bit	From KNX

Target value while switching on slumber function

This value is reached after receipt of an ON telegram via object 21 at the output of the dimmer after completion of the dimming process.

Target value while switching off slumber function

This value is reached after receipt of an OFF telegram via object 21 at the output of the dimmer after completion of the dimming process.

Fade time on 1. ON telegram (1. button press, related to 100%)

This dimming time is used to dim to the final value for switching on after pressing the 1st button. The time period is related to a complete dimming process from 0 – 100 %.

Fade time on 2. ON telegram (2. button press, related to 100%)

This dimming time is used to dim to the final value for switching on after the 2nd button is pressed. The time period is related to a complete dimming process from 0 – 100 %.

Fade time on 1. OFF telegram (1. button press, related to 100%)

This dimming time is used to dim to the final value for switching off after the 1st key is pressed. The time period is related to a complete dimming process from 0 – 100 %.

Fade time on 2. OFF telegram (2. button press, related to 100%)

This dimming time is used to dim to the final value for switching off after the 2nd button is pressed. The time period is related to a complete dimming process from 0 – 100 %.

6.11 Dimmer A: Lock function

If the lock function is activated, the following objects are active:

Group object	Type KNX	Size	Direction
GO 22 Dimmer A: Lock – Activate	1.001	1 bit	From KNX
GO 23 Dimmer A: Prior. dimming on/off – Switch	1.001	1 bit	From KNX
GO 24 Dimmer A: Prior. dimming rel. – Brighter/Darker	3.007	4 bits	From KNX
GO 25 Dimmer A: Prior. dimming abs. – Set value	5.001	1 byte	From KNX

If the lock has been activated via group object 22, other received telegrams for dimmer, automatic mode, slumber, scene function and sequencer are not executed.

In addition to the disable object, 3 priority objects become visible when the disable function is activated, with which the dimmer can be controlled independently of the disable. In this way, it is possible to set an initial state without influencing other functions.

Example of priority objects:

At events in public buildings or in restaurants, the buttons can be disabled after regular operation by means of the disable object. This makes it possible to block buttons that are accessible to unauthorised persons during the lecture or concert in order to prevent unintentional switching. Nevertheless, the organiser can, if necessary, control the individual lamps with the help of the priority object without lifting the lock.

Polarity of object

The object's mode of action can be used to set how the lock is to be activated – either by receiving a 1 or by receiving a 0.

The choices are:

- Lock active on 1
- Lock active on 0

Behavior on start

Here you can configure the state that is set when the lock is activated at the output.

The choices are:

- No reaction
- Dimm to value

The state of the output can be further changed by the priority objects.

Behavior at end

Here you can configure the state that is set when the lock is deactivated at the output.

The choices are:

- No reaction
- Dimm to value

- State before lock

Here the original state before activation of the lock is restored. Telegrams received during the lock are ignored.

- State without lock

Here the state of the last received telegram is restored. This means that the received telegrams are taken into account during the lock. Thus, when the lock is deactivated, the state of the last received telegram is set.

6.12 Dimmer A: Sequencer

--- KNX IO 546.1 secure (1D10) > Channel A: Dimmer > Dimmer A: Sequencer

Description	Steps of sequencer	3
General settings	Resume sequence after man. operation	Only by object
	Step after man. operation	Active step
Channel A: Dimmer	Polarity of object "Sequence on/off"	<input type="radio"/> Switch on with 0 <input checked="" type="radio"/> Switch on with 1
	Behavior on switching on	No reaction
	Behavior on switching off	Complete actual step
	<hr/> Step 1:	
+ Channel B: Actuator	Start by time	<input checked="" type="radio"/> Disabled <input type="radio"/> Start by time of day
	Start by ON/OFF telegram	<input checked="" type="radio"/> Disabled <input type="radio"/> Enabled
	Start by scene number	<input checked="" type="radio"/> Disabled <input type="radio"/> Enabled
	Action	Brightness
	Brightness	100 %
	Fade time (related to 100%)	00:00:00 hh:mm:ss
	<hr/> Step 2:	
	Start by time	Start after last trigger
	Start time	00:00:01 hh:mm:ss
	Start by ON/OFF telegram	<input checked="" type="radio"/> Disabled <input type="radio"/> Enabled
Start by scene number	<input checked="" type="radio"/> Disabled <input type="radio"/> Enabled	
+ Logic / Timer	Action	Brightness
	Brightness	10 %
	Fade time (related to 100%)	00:00:00 hh:mm:ss
	<hr/> Step 3:	
	Start by time	Start after last trigger
	Start time	00:00:01 hh:mm:ss
	Start by ON/OFF telegram	<input checked="" type="radio"/> Disabled <input type="radio"/> Enabled
	Start by scene number	<input checked="" type="radio"/> Disabled <input type="radio"/> Enabled
	Action	Start loop
	Start loop at	<input checked="" type="radio"/> Step 1 <input type="radio"/> Step 2
Limitation of loops	<input checked="" type="radio"/> Unlimited <input type="radio"/> Limited	

The sequencer can be used to create complex sequence programs consisting of up to 32 individual steps for the dimmer channel. The activation of the individual steps is possible at the following start conditions:

- At a fixed time
- After a waiting time to a previous step
- Via on/off telegram
- On receipt of a parameterized scene number

When a step is activated, a value can be dimmed or a scene number can be sent. In addition, a step or an entire step sequence can be repeated cyclically.

The following objects are available for general control of the sequencer:

Group object	Type KNX	Size	Direction
GO 33 Dimmer A: Sequence suspend – Suspend/Resume	1.001	1 bit	From KNX
GO 34 Dimmer A: Sequence on/off – Switch	1.001	1 bit	From KNX

Steps of sequencer

Number of steps (0 ... 32) to be used.

Resume sequence after man. operation

A sequence that is switched on can always be interrupted or continued via object 33; an ON telegram interrupts the sequence, an OFF telegram continues it.

A sequence is also interrupted after manual operation, i.e. after commands for dimmer, automatic mode, slumber or scene function.

In addition, this parameter determines how an interrupted sequence can still be continued, is available for selection:

- Only by object
The sequence can only be continued via object 33.
- After off-time
The sequence is continued after the set blocking time.
- On next activated step
The sequence is continued at the next activated step. The next step can be activated via object or time-controlled.

Off-time

Only visible if the sequence is to be continued after off-time, this blocking time can be configured with this.

Step after man. operation

This step is executed when resuming after manual operation, the function of the set step is always executed, regardless of its other set start conditions.

Polarity of object “Sequence on/off”

This parameter can be used to set which telegram value can be used to switch the sequence on and off via object 34. If the sequence is switched off, any further activation of a step is blocked.

Behavior on switching on

This determines how the sequencer behaves when switched on via object 34 is available for selection:

- No reaction
No function is executed, the sequencer is waiting for steps to be activated.
- Step 1 – 32
The function of the step is executed (regardless of the other set start conditions of the step), the sequence is then continued according to its configuration from this step.

Switching on also reactivates a sequence interrupted by manual operation.

Behavior on switching off

This determines how the sequencer behaves when switched off via object 34 is available for selection:

- Complete actual step
If the sequencer is in a dimming process, this is still being completed.
- Step 1 – 32
The function of the step is executed (regardless of the other start conditions set for the step).
- Stop immediately
If the sequencer is in a dimming process, this is stopped.

Apart from the set behavior at power off, any further activation of a step after power off is disabled until the sequencer is switched on again via object 34.

Step 1 – 32

Step 2:	Step 2
Start by time	Start after last trigger
Start time	00:00:01 hh:mm:ss
Start by ON/OFF telegram	<input type="radio"/> Disabled <input checked="" type="radio"/> Enabled
Start by scene number	<input type="radio"/> Disabled <input checked="" type="radio"/> Enabled
Start scene	2
Action	Brightness
Brightness	10 %
Fade time (related to 100%)	00:00:00 hh:mm:ss

When a step is activated, its parameters appear for configuration.

You can enter your own name for the step in the text field at the top right with the content "Step x". This designation is used for better orientation of the user and has no influence on the functionality of the step.

Start by time

This parameter is used to configure a time start condition of the step, available for selection:

- Disabled
Start condition not used.
- Start by time of day
The time at which the step is to start can be entered here. When using this start condition, the current time must have been received via the following object:

Group object	Type KNX	Size	Direction
GO 5 Time of Day – Set	10.001	3 bytes	From KNX



If no valid time has been specified via object 5, all start conditions at fixed times are not active.



The time is continuously updated by the device through its internal timer, but due to component tolerances there is always a deviation from the actual time. Therefore, the current time should be sent to the device at least twice a day by a precise timer in order to keep the deviation as small as possible.

- Start after last trigger
Here you can specify the time interval to wait after the previous activation before executing the step. This start condition is not available for step 1.

Start time

Here either the time or the waiting time can be specified for the execution of the current step, if a timed start condition is used.

Start by ON/OFF telegram

When using this start condition, a separate object is available for each step:

Group object	Type KNX	Size	Direction
GO 35 – 66 Dimmer A: Sequence Step 1 – 32 on/off – Switch	1.001	1 bit	From KNX

An ON telegram to one of these objects activates the respective step, the sequence is then continued from this step according to its configuration.

An Off telegram also activates this step, but resets the sequence at the same time.

Start by scene number

When this start condition is used, the following object becomes visible:

Group object	Type KNX	Size	Direction
GO 31 Dimmer A: Sequence scene – Activate step	18.001	1 byte	From KNX

A telegram with the set scene to one of these objects activates the respective step, the sequence is then continued according to its configuration from this step.

All steps with this start condition are controlled via this object.

Action

When the step is activated, the configured function is executed:

- None
No function is executed. This can be used, for example, to implement a switch-on delay of a sequence.
- Start loop
The sequence is continued at the selected step. Parameters for the start step of the loop and number of loops become visible.

- Send scene number

When using this function, the following objects become visible:

Group object	Type KNX	Size	Direction
GO 32 Dimmer A: Sequence scene – Send scene	18.001	1 byte	To KNX

A parameter for the sent scene number becomes visible; when the step is activated, this scene number is sent via the respective object.

All steps send the scene number via one of these objects if this function is used for the respective step.

- Brightness
Parameters for brightness and fade time become visible. When the step is activated, the dimmer dims from the current value to the specified brightness with the parameterized fade time. This time is related to a complete dimming process from 0 – 100 %.



*The fade time must be shorter than or equal to the **start time** or waiting time of the next step in order to achieve the set brightness.*

6.13 Actuator B: General

--- KNX IO 546.1 secure (1D10) > Channel B: Actuator > Actuator B: General

Description	Name	<input type="text"/>
General settings	Function	Universal output
+ Channel A: Dimmer	Scene function	<input checked="" type="radio"/> Disabled <input type="radio"/> Enabled
- Channel B: Actuator	Send state	Cyclic and on change
Actuator B: General	Time for cyclic state	6 hour
+ Logic / Timer	Behavior on bus power failure	No reaction
	Behavior after bus power return	State like before bus power failure
	Lock function	<input checked="" type="radio"/> Disabled <input type="radio"/> Enabled

Name (30 characters)

An arbitrary name can be assigned for the channel. However, this should be clear and meaningful, this makes it easier to work with the associated group objects, because the given name is displayed there as a label. If no name is assigned, the group objects are named “Actuator B: ...”.

Function

This parameter defines the functionality of the actuator. The following options are selectable:

- Disabled
- Switch dimmer
- Universal output
- On/Off delay
- Staircase function
- Valve actuator (PWM for thermal servo)



More detailed descriptions of the functions can be found in the sections “Actuator B: ...”.

Delay before switching off the relay [sec.] (only for function “Switch dimmer”)

To avoid frequent switching off, a delay time before switching off can be defined here.

Scene function (only for function “Universal output”)

With this parameter the scene function can be enabled or disabled. If this functionality is enabled, the respective group object as well as the parameter page “Actuator B: Scene function” are displayed for further configuration of scenes 1 – 16.

Group object	Type KNX	Size	Direction
GO 72 Actuator B: Scene – Activ./Lrn.	18.001	1 bit	From KNX

Behavior on bus power failure (for function != “Disabled” or “Switch dimmer”)

The behavior which is held at the output during the bus power failure can be configured here.

The following options are selectable:

- No reaction
- Switch on
- Switch off

Behavior after bus power return (for function != “Disabled” or “Switch dimmer”)

Here the behavior of the output after bus power return can be configured. This behavior will be set after every device restart (e.g. also on restart after ETS download).

The following options are selectable:

- No reaction
- Switch on
- Switch off
- State like before bus power failure

Send state (for function != “Disabled” or “Switch dimmer”)

This parameter defines the behavior of the state objects:

- Disabled
State objects are deactivated and not displayed
- Only on read
State objects send only on request
- On change
State objects send on value change
- Cyclic and on change
State objects send cyclically and on value change

Group object	Type KNX	Size	Direction
GO 78 Actuator B: Output – State	1.001	1 bit	To KNX
GO 79 Actuator B: Valve actuator (PWM) – State*	5.001	1 byte	To KNX

* for function = “Valve actuator (PWM for thermal servo)”

Time for cyclic state (for function != “Disabled” or “Switch dimmer”)

Is selected state object “Cyclic and on change”, in this parameter the cycle time can be set.

Lock function (for function “Universal output”, “On/Off delay” or “Staircase function”)

With this parameter the lock function can be enabled. If this functionality is activated, the associated group objects as well as the parameter page “Actuator B: Lock function” are displayed for further configuration. If the lock has been activated via the group object “Lock”, the received switching telegrams are not executed.

In addition to the lock object, there is also a priority object, which can be switched independently of the lock. Thus, it is possible to set an output state without affecting other functions.

Group object	Type KNX	Size	Direction
GO 75 Actuator B: Lock – Activate	1.001	1 bit	From KNX
GO 76 Actuator B: Prior. output – Switch	1.001	1 bit	From KNX

Lock function (for function “Valve actuator (PWM for thermal servo)”)

With this parameter the lock function can be disabled or enabled. If this functionality is activated, the associated group objects as well as the parameter page “Actuator B: Lock function” are displayed for further configuration. If the lock has been activated via the group object “Lock”, the received switching telegrams are not executed.

In addition to the lock object, there is also a priority object, which can be used to set a control value independently of the lock. Thus, it is possible to set an output PWM without affecting other functions.

When the lock is ended, the last received value (not priority object) is represented as PWM at the output.

Group object	Type KNX	Size	Direction
GO 75 Actuator B: Lock – Activate	1.001	1 bit	From KNX
GO 77 Actuator B: Prior. valve actuator (PWM) – Control value	5.001	1 byte	From KNX

Example of the priority object:

In the case of events in public buildings or in restaurants, the normal operation can be set into an inoperative state by the lock group object. Thus it is possible to lock during the lecture or concert, switches that are accessible to unauthorized persons, in order to prevent unmeant switching. Nevertheless, the individual lamps can controlled by use of the priority object without canceling the lock.

6.14 Actuator B: Lock function

Condition:

Function is “Universal output”, “On/Off delay” or “Staircase function”.

The screenshot shows the configuration interface for Actuator B: Lock function. The breadcrumb path is: --.- KNX IO 546.1 secure (1D10) > Channel B: Actuator > Actuator B: Lock function. The interface is divided into a left sidebar and a main configuration area. The sidebar contains the following items: Description, General settings, Channel A: Dimmer (expanded), Channel B: Actuator (expanded), Actuator B: General, Actuator B: Lock function (selected), and Logic / Timer (expanded). The main configuration area has three rows: 1. Polarity of object: Radio buttons for 'Lock active on 1' (selected) and 'Lock active on 0'. 2. Behavior on start: A dropdown menu set to 'No reaction'. 3. Behavior at end: A dropdown menu set to 'No reaction'.

Polarity of object

This parameter defines, if the lock should be activated by receiving a 1 or by receiving a 0.

The following options are selectable:

- Lock active on 1
- Lock active on 0

Behavior on start

This parameter configures, which state the output should set, if the lock activates.

The following options are selectable:

- No reaction
- Switch on
- Switch of

This output state can still be changed by the priority object.

Behavior at end

This parameter defines, which state the output should set, if the lock deactivates.

The following options are selectable:

- No reaction
- Switch on
- Switch off

- State before lock
This restores the original state before the lock was activated. Switching telegrams received during the lock are ignored.

- State without lock
Here the state of the last received switching telegram is restored. This takes into account the received switching telegrams during the lock. Thus, when the lock is deactivated, the last received switching telegram is set.

Condition:

Function is “Valve actuator (PWM for thermal servo)”.

The screenshot shows a configuration window for 'Actuator B: Lock function' within a KNX IO 546.1 secure (1D10) system. The window has a sidebar on the left with a tree view containing: Channel A: Dimmer, Channel B: Actuator (expanded), Actuator B: General, Actuator B: Valve actuator, Actuator B: Lock function (selected), and Logic / Timer. The main area contains the following settings:

- Description:** Polarity of object. Radio buttons for 'Lock active on 1' (selected) and 'Lock active on 0'.
- General settings:** Behavior on start. Radio buttons for 'No reaction' and 'Value' (selected).
- Control value (PWM):** A dropdown menu currently set to '50 %'.

Polarity of object

This parameter defines, if the lock should be activated by receiving a 1 or by receiving a 0.

The following options are selectable:

- Lock active on 1
- Lock active on 0

Behavior on start

This parameter defines, which behavior the output should represent, if the lock activates.

The following options are selectable:

- No reaction
The PWM value remains as to begin of the lock function.
- Value
When the lock is activated, a defined PWM value is represented on the output.

Control value (PWM)

If a defined PWM value should be set to the output when the lock is activated, this value can be set with this parameter.

6.15 Actuator B: Switch dimmer

The function “Switch dimmer” is used, for example to switch a dimmer power supply automatically. With a dimming value of 0 % the relay switches off, with a dimming value > 0 % it switches on.

6.16 Actuator B: Universal output

If the universal output is selected on the parameter page “Actuator B: General”, the actuator can be used as a switching output. A parameter for the scene function is also displayed.

Group object	Type KNX	Size	Direction
GO 71 Actuator B: Output – Switch	1.001	1 bit	From KNX

6.17 Actuator B: Scene function

--- KNX IO 546.1 secure (1D10) > Channel B: Actuator > Actuator B: Scene function

Description	Scene 1	Switch on
General settings	Number	1
+ Channel A: Dimmer	Scene 2	Switch off
- Channel B: Actuator	Number	2
Actuator B: General	Scene 3	Learnable
Actuator B: Scene function	Number	3
+ Logic / Timer	Scene 4	No reaction
	Scene 5	No reaction
	Scene 6	No reaction
	Scene 7	No reaction
	Scene 8	No reaction
	Scene 9	No reaction
	Scene 10	No reaction
	Scene 11	No reaction
	Scene 12	No reaction
	Scene 13	No reaction
	Scene 14	No reaction
	Scene 15	No reaction
	Scene 16	No reaction

Scene 1 – 16

These parameters can be used to configure the state, which is set at the output when the respective scene is executed.

The following options are selectable:

- No reaction
- Switch on
- Switch off
- Learnable

By using a scene control telegram, the current state at the output can be saved for the respective scene. This allows the user to customize the scene without ETS download.

Number

This parameter sets any scene number between 1 and 64 to the scene. There must not configured any scene numbers twice.

6.18 Actuator B: On/Off delay

--- KNX IO 546.1 secure (1D10) > Channel B: Actuator > Actuator B: On/Off delay

Description	On delay time	2 s
General settings	Retriggerable	<input checked="" type="radio"/> Disabled <input type="radio"/> Enabled
+ Channel A: Dimmer	Off delay time	30 s
- Channel B: Actuator	Retriggerable	<input checked="" type="radio"/> Disabled <input type="radio"/> Enabled
Actuator B: General		
Actuator B: On/Off delay		
+ Logic / Timer		

If the on/off delay is selected on the parameter page “Actuator B: General”, delayed switching times can be configured. The “Actuator B: On/Off Delay” parameter page is displayed for this purpose.

Group object	Type KNX	Size	Direction
GO 71 Actuator B: Output – Switch	1.001	1 bit	From KNX

On delay time

The duration of the switch-on delay is configured in this parameter.

Input: --1-----0-----

Output: -- | -T-1-----0-----

Off delay time

The duration of the switch-off delay is configured in this parameter.

Input: --1-----0-----

Output: --1----- | -T-0--

Retriggerable

If these parameters are activated, the respective delay time is restarted upon receipt of the corresponding switching signal.

6.19 Actuator B: Staircase function

--- KNX IO 546.1 secure (1D10) > Channel B: Actuator > Actuator B: Staircase function

Description	Switch off time	10 min
General settings	Retriggerable	<input type="radio"/> Disabled <input checked="" type="radio"/> Enabled
+ Channel A: Dimmer	Reaction on 'OFF' telegram	<input checked="" type="radio"/> Switch off <input type="radio"/> Ignore
- Channel B: Actuator	Time for warning before switch off	10 s
Actuator B: General	Time of interrupt	500 ms
Actuator B: Staircase function		
+ Logic / Timer		

If the staircase function is selected on the parameter page “Actuator B: General”, a group object for the staircase function appears in addition to the normal switching object. Via the additional parameter page “Actuator B: Staircase function” this function can be configured.

Group object	Type KNX	Size	Direction
GO 71 Actuator B: Output – Switch	1.001	1 bit	From KNX
GO 73 Actuator B: Staircase function – Trigger	1.010	1 bit	From KNX

Switch off time

The time for which the output is activated after an ON telegram (object of the staircase function) has been received, can set in this parameter.

Input: --1-----0-----

Output: --1-T-0-----

Retriggerable

This parameter can be used to set whether the follow-up time is to be restarted when an ON telegram is received on the object of the staircase function.

Reaction on ‘OFF’ telegram

This parameter can be used to set whether an OFF telegram on the object of the staircase function should be processed or ignored.

Time for warning before switch off

The time between pre-warning and deactivation is configured, or the pre-warning is deactivated with this parameter. If the pre-warning time is longer than the actual follow-up time, no pre-warning is carried out.

Time of interrupt

The pre-warning is indicated by a brief interruption (switch off – switch on). The duration of this interrupt is configured in this parameter.



LED lamps often have a long follow-up time, in which the lamp still lights even though it is already switched off. With such lamps longer interrupt times must be set to generate a “visible” interruption.

6.20 Actuator B: Valve actuator (PWM for thermal servo)

--- KNX IO 546.1 secure (1D10) > Channel B: Actuator > Actuator B: Valve actuator

Description	Cyclic time (PWM)	15 min
General settings	Maximum control value (PWM)	100 %
+ Channel A: Dimmer	Stuck protection	<input type="radio"/> Disabled <input checked="" type="radio"/> Enabled
- Channel B: Actuator	Execution time	5 min
Actuator B: General	Monitoring interval	7 day
Actuator B: Valve actuator	Protection on missing control value	<input type="radio"/> Disabled <input checked="" type="radio"/> Enabled
+ Logic / Timer	Protection control value (PWM)	10 %
	Monitoring interval	2 hour

The function valve actuator is foreseen to control thermoelectric valve drives which are used for floor heating but also for radiators. It maps the continuous position (0 % – 100 %) to an ongoing On/Off sequence called PWM (pulse width modulation) signal.

If the valve actuator is selected on the parameter page “Actuator B: General”, a group object for the valve actuator appears instead of the normal switching object. This allows the current PWM at the output to be set via KNX (0 % – 100 %). An additional parameter page “Actuator B: Valve actuator” appears for the configuration of the valve actuator.

The received control value is saved automatically by the device, to continue faultless after a possible bus power loss.

Group object	Type KNX	Size	Direction
GO 74 Actuator B: Valve actuator (PWM) – Control value	5.001	1 byte	From KNX

Cyclic time (PWM)

The cyclic time of the PWM, which is used to control a servo drive, is configured with this parameter. One cycle involves a time range in which the output is switched on and one in which the output is switched off. The cyclic time corresponds to the period between two rising edges (state change at the output from OFF to ON). The longer the flow of the heating circuit (tube / pipe length), the higher the cyclic time should be set.



Typical thermal servo require several minutes for a valve change of 100 %.

Maximum control value (PWM)

This parameter can be used to limit the maximum control value. The control value is expressed in percent and defines the period during which the output is switched on in one cycle.

Example:

Cyclic time = 10 min

Maximum control value (PWM) = 80 %

Maximal output state = ON for 8 min / OFF for 2 min

Stuck protection

With the stuck protection, it is intended to prevent the valve from being damaged by corrosion or calcification, that it can no longer be moved. In case stuck protection is enabled, this is only triggered if the value is permanently 0 % or 100 %. On every other control value the servo already moves, so there is no need for a stuck protection.

Example:

Control value 0 % = Open servo for the set time

Control value 100 % = Close servo for the set time



In case the valve is not allowed to open, the stuck protection must be disabled.

Execution time *(only for activated stuck protection)*

If the stuck protection is activated, this parameter is used to set the duration of the state change.

Monitoring interval *(only for activated stuck protection)*

If the stuck protection is activated, this parameter sets the monitoring interval. If the state of the output remains unchanged for this time, the lock protection is triggered.

Protection on missing control value

This parameter enables the protection function on missing control value telegrams. This is necessary in order to prevent unwanted and uncontrolled overheating or cooling down of the room, when the control value is missing.

Protection takes effect, as soon as no telegrams are received from the controller over a longer period of time. As soon as this extended telegram pause has occurred, it can be assumed that the corresponding controller has failed or the connection between the controller and the valve actuator has been interrupted.

Protection control value (PWM) *(only for activated protection on missing control value)*

If the protection on missing control value is enabled, this parameter sets a protection control value. This configured PWM value will set the output, if the protection is active.

As soon as telegrams from the controller are received again, the protection control value (PWM) is overwritten by the received value. The protection does not react again, until the waiting time in the set monitoring interval is exceeded between individual telegrams.

Monitoring interval *(only for activated protection on missing control value)*

If the protection on missing control value is enabled, this parameter sets the monitoring interval. If no further telegram is received by the device during this time, the protection function takes effect.

6.21 Logic / Timing

--- KNX IO 546.1 secure (1D10) > Logic / Timer > Logic / Timer		
Description	Function 1	Timer
General settings	Function 2	Timer
+ Channel A: Dimmer	Function 3	Logic
+ Channel B: Actuator	Function 4	Logic
- Logic / Timer	Function 5	Disabled
	Function 6	Disabled
	Function 7	Disabled
	Function 8	Disabled
	Function 9	Disabled
	Function 10	Disabled
	Function 11	Disabled
	Function 12	Disabled
	Function 13	Disabled
	Function 14	Disabled
	Function 15	Disabled
	Function 16	Disabled

Function 1 – 16

These parameters contain the functions timer and logic, whereby all 16 functions are identical.

The following options are available:

- Disabled
No parameters and group objects for timer and logic.
- Timer
Parameters and group objects for timer are available.
- Logic
Parameters and group objects for logic are available.



The functions for timer and logic can be linked to one another by means of the associated group objects. This also allows to create complex structures. For this purpose, the output of a function is set to the same group address as the input of the next function.

6.22 Function 1 – 16: Timer

--- KNX IO 546.1 secure (1D10) > Logic / Timer > Function 1: Timer

Description	Function name	<input type="text"/>
General settings	Timer type	Switch-on delay ▼
+ Channel A: Dimmer	Delay time [s]	60 ▲▼
+ Channel B: Actuator	Output	<input checked="" type="radio"/> Not inverted <input type="radio"/> Inverted
- Logic / Timer		
Logic / Timer		
Function 1: Timer		
Function 2: Timer		
Function 3: Logic		
Function 4: Logic		

Function name (10 characters)

The function name can be chosen freely.

The name is visible in the group object entry in the ETS software. This makes it easier to work with the associated group objects, because the given name is displayed there as a label.

Timer type

Here the type of the timer can be set:

- Switch-on delay

The ON telegram (1) received on the input is delayed on the output.

Input: --1-----0-----

Output: -- | -T-1-----0-----

Group object	Type KNX	Size	Direction
Timer – Switch-on delayed – Input	1.002	1 Bit	From KNX
Timer – Switch-on delayed – Output	1.002	1 Bit	To KNX

- Switch-off delay

The OFF telegram (0) received on the input is delayed on the output.

Input: --1-----0-----

Output: --1----- | -T-0--

Group object	Type KNX	Size	Direction
Timer – Switch-off delayed – Input	1.002	1 Bit	From KNX
Timer – Switch-off delayed – Output	1.002	1 Bit	To KNX

- Switch-on and -off delay

The ON/OFF telegram (1/0) received on the input is delayed on the output.

Input: --1-----0-----

Output: -- | -T-1----- | -T-0--

Group object	Type KNX	Size	Direction
Timer – Switch-on/off delayed – Input	1.002	1 Bit	From KNX
Timer – Switch-on/off delayed – Output	1.002	1 Bit	To KNX

- Impulse (staircase)

The ON telegram (1) received on the input is sent on the output. After a delay the output sends the OFF telegram (0).

Input: --1-----0-----

Output: --1-T-0-----

Group object	Type KNX	Size	Direction
Timer – Impulse (staircase) – Input	1.002	1 Bit	From KNX
Timer – Impulse (staircase) – Output	1.002	1 Bit	To KNX



Each timer can be stopped by sending the opposite value to its input group object. For example: An already started switch-on timer can be stopped by sending OFF (0) to its input group object.

Delay [s]

This parameter defines the delay when sending at the output.

Output

Via this parameter the sent value on the output can be inverted:

- Not inverted
- Inverted

6.23 Function 1 – 16: Logic

--- KNX IO 546.1 secure (1D10) > Logic / Timer > Function 3: Logic

Description	Function name	<input type="text"/>
General settings	Gate type	AND gate
+ Channel A: Dimmer		
+ Channel B: Actuator		
- Logic / Timer		
Logic / Timer		
Function 1: Timer		
Function 2: Timer		
Function 3: Logic		
Function 4: Logic		

Function name (10 characters)

The function name can be chosen freely.

The name is visible in the group object entry in the ETS software. This makes it easier to work with the associated group objects, because the given name is displayed there as a label.

Gate type

This parameter defines the type of the logic gate:

- **And gate**
The output is triggered ON (1), if both inputs are switched ON (1).
- **OR gate**
The output is triggered ON (1), if one or both inputs are switched ON (1).
- **XOR gate**
The output is triggered ON (1), if the two inputs are not equal.
- **NAND gate**
The output is triggered ON (1), if one or both inputs are switched OFF (0).
- **NOR gate**
The output is triggered ON (1), if both inputs are switched OFF (0).
- **XNOR gate**
The output is triggered ON (1), if both inputs are equal.

Group object	Type KNX	Size	Direction
Logic – Gate input A – Input	1.002	1 Bit	From KNX
Logic – Gate input B – Input	1.002	1 Bit	From KNX
Logic – Gate output – Output	1.002	1 Bit	To KNX



The output transmits when a telegram is received on one of the inputs. A precondition for this is that both inputs are valid (have received at least one telegram). The output sends a 1 if the respective condition is fulfilled, otherwise a 0.

- **INVERTER**
Input ON (1) is converted into output OFF (0). Input OFF (0) is converted into output ON (1).

Group object	Type KNX	Size	Direction
Logic – Gate input – Input	1.002	1 Bit	From KNX
Logic – Gate output – Output	1.002	1 Bit	To KNX



The output transmits when a telegram is received on the input.



WARNING

- The device must be mounted and commissioned by an authorized electrician.
- The prevailing safety rules must be heeded.
- The device must not be opened.
- For planning and construction of electric installations, the relevant guidelines, regulations and standards of the respective country are to be considered.
- The device is a permanently connected equipment: A readily accessible disconnect device shall be incorporated external to the equipment.
- The installation requires a 16 A fuse for external overcurrent protection.
- The power rating is indicated on the side of the product.



ETS5 Database

www.weinzierl.de/en/products/546.1/ets5

Data sheet

www.weinzierl.de/en/products/546.1/datasheet

CE Declaration

www.weinzierl.de/en/products/546.1/ce-declaration

WEINZIERL ENGINEERING GmbH

Achatz 3-4
84508 Burgkirchen an der Alz
GERMANY

Tel.: +49 8677 / 916 36 – 0
E-Mail: info@weinzierl.de
Web: www.weinzierl.de

2022-03-15